



ELECTRIC
TIME AND PROGRAM CLOCK SYSTEMS
SELF-WINDING CLOCKS
EMERGENCY LIGHTING SYSTEMS

DESCRIPTIVE CATALOGUE
With
SPECIFICATIONS and DATA
For
ARCHITECTS and ENGINEERS

LANDIS ENGINEERING AND MFG. CO.
CLOCK DIVISION
WAYNESBORO, PENNA. U. S. A.

"Reproduced from an original catalogue
in the Library of John D. Herman, M.D.,
Bethesda, Maryland U.S.A."

LANDIS ENGINEERING AND MFG. CO.

CLOCK DIVISION

Manufacturers of Electric Time and Program Clock Systems

WAYNESBORO, PA.

Products

ELECTRIC TIME and PROGRAM CLOCK SYSTEMS, complete with all accessories, as Secondary Clocks, Program Machines, Push Button Boards, Time Stamps, Laboratory Clocks, Street Clocks, Tower Clocks, Time Recorders, Bells, Buzzers, Gongs, Time Switches and Fire Alarm Systems for use in schools, colleges, public buildings, industrial plants where *accurate time and signal work* is desired.

INDIVIDUAL ELECTRIC SELF-WINDING CLOCKS operated from 110 volt a-c. or d-c. supply or single dry cell supply.

EMERGENCY LIGHTING SYSTEMS for theaters, schools or auditoriums.

The Landis Line

The present Landis line is the development of over forty years. Simplicity, ruggedness and economy have been the ends sought in developing our product.

Thousands of installations throughout every State in the Union and many foreign countries are in constant service in schools and colleges, industrial plants and residences.

No matter how complicated your time and signal requirements may be, our Engineering Department is at your service.

The details of the service of our Engineering Department are covered in a subsequent heading.

Most of our customers have selected Landis equipment as the result of meritorious performance, rather than from the standpoint of price.

Master Clocks

The Master Clock of an electric time and program clock system must be what the name implies, "master." For accurate time and real precision, the master clock must be so constructed that there shall be accuracy and simplicity in the design to insure long life. A watch or clock can be well likened to the human heart, as it is required to be in service night and day throughout its lifetime.

The design of the Landis Master Clock movement is a marked departure from the conventional electric clock movement. The movement is weight driven, electrically wound. The electrical energy necessary to wind the clock is but $\frac{1}{2}$ of 1% of that necessary



to wind the average self-winding master regulator movement.

There are no delicate adjustments to be made in the movement to insure its satisfactory operation.

Details of Mechanism—There is but *one* contact or circuit closer in the Landis Master Clock movement for the operation of all secondarily operated equipment, whilst many movements have

as many as four distinct circuit closers to operate the secondary or auxiliary units of a system. The contact or circuit closer is non-adjustable, which insures a constant length, positive wiping, contact at each impulse, applicable to any "beat" of movement, either 60, 80 or 120-beat.

The movement is shown in the accompanying illustration, regularly furnished in 60, 80 and 120-beat movements.

The Graham dead beat escapement is used, with accurately *cut* gear train, hardened burnished pivots, with maintaining power spring to provide constant driving power at all times.

The self-compensating cam system used in winding the Landis Master Clock movement is a patented design which makes the most efficient construction possible. An examination of details in illustration will show the simplicity of the design.

All pendulums used on Landis master regulator movements are accurately compensated so that accurate regulation can be secured on any of the movements, 60, 80 or 120-beat. Regulation can be secured within 30 seconds per month on any of the wooden rod and metal bob pendulums.

Where extreme accuracy is desired, within 10 seconds per month, a double cup mercurial pendulum is advised. Same only furnished for 60-beat movements.

Movements are mounted in a number of different styles of cases, as shown on following pages; all made of the best quality of wood, dependent upon the individual requirements of the customer. Standard cases are furnished in quartered oak, however, wal-

nut, birch, mahogany or cherry can be furnished. All cases are finished in accordance with best cabinet practice.

Special finishes to match interior trim can likewise be furnished, to order.

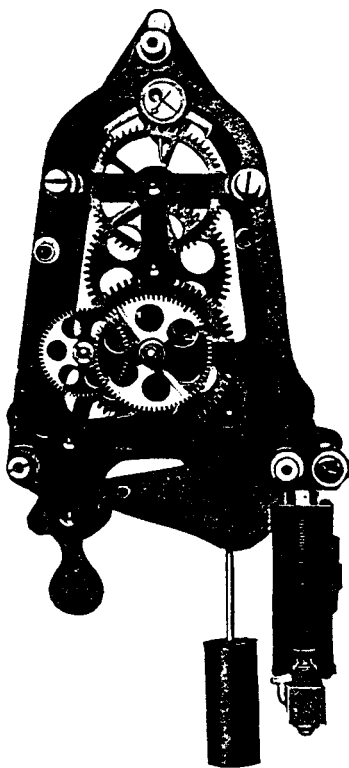

Landis Self-winding Master Clock Movement

Style A Master Clock Cases

Below are the standard 60-beat Master Clock cases of the hanging wall type, with 12-in. white enamel dials, Roman or Arabic numerals.

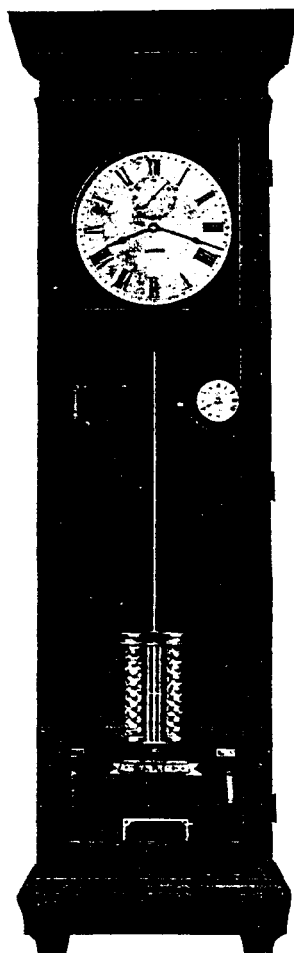

Style A60TD
69 1/2 x 21 1/2 x 9 1/2 in.

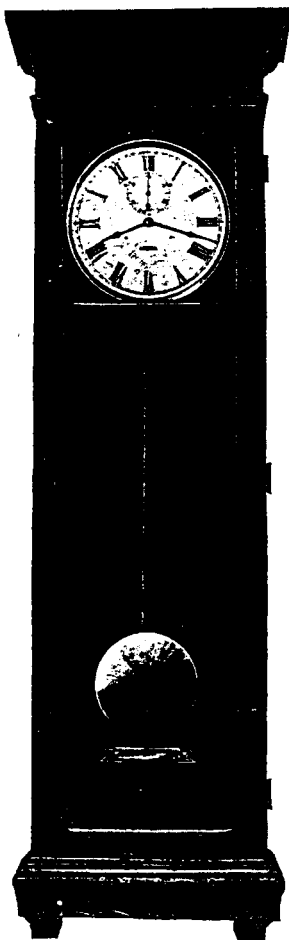

Style A60T
69 1/2 x 27 1/2 x 9 1/2 in.

The Style A cases are equipped with 60-beat self-winding master clock movements. Style A60TD shows the double cup mercurial compensating pendulum, used for extremely accurate regulation within 10 seconds per month. Style A60T shows the standard wooden rod and metal bob pendulum capable of regulation to within 30 seconds per month.

In specifying a case the prefix letter indicates the style of case; the numeral 60, 80 or 120, the beat of movement; the suffix letters as T, F, S and D indicate as follows:

T=Equipped for the control of secondarily operated equipment as secondary clocks, time stamps, one-minute interval program machines, etc.

F=Equipped for the operation of a five-minute interval program machine.

S=Equipped for the operation of a seconds contact for laboratory clocks, etc.

D=Double cup mercurial pendulum.

The absence of a suffix letter indicates a plain self-winding timepiece.

A suffix numeral after the suffix letter indicates the voltage of the current supply, as A60TD-12 indicates a Style A case, 60-beat self-winding regulator, equipped for the control of secondarily operated equipment, double cup mercurial pendulum, operated from a 12-volt current supply.

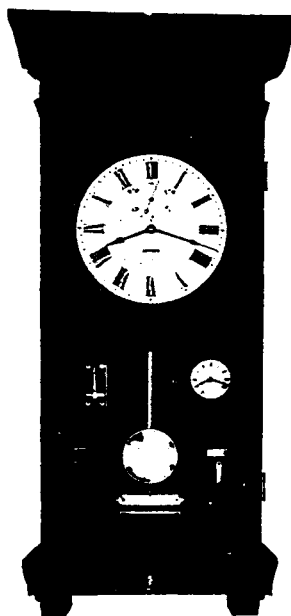

Style B80T
47 x 21 1/2 x 9 1/2 in.

Style B Master Clock Case

The same general specifications that apply to movements for Style A cases apply to the Style B case as shown, except that the B case uses an 80-beat movement.

Floor Type Master Clock Cases

Some typical examples of floor type Master Clock cases are shown below as M60TD and F60TD.

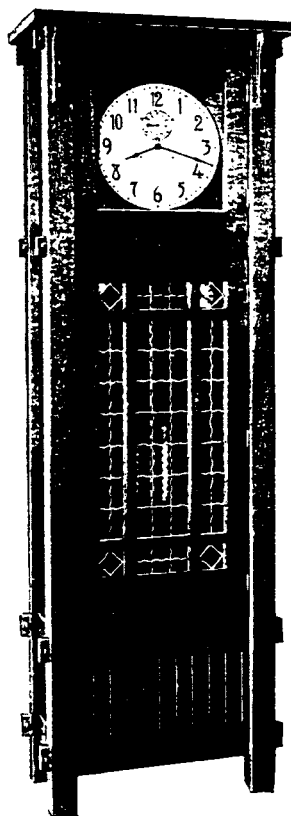

Style M60TD

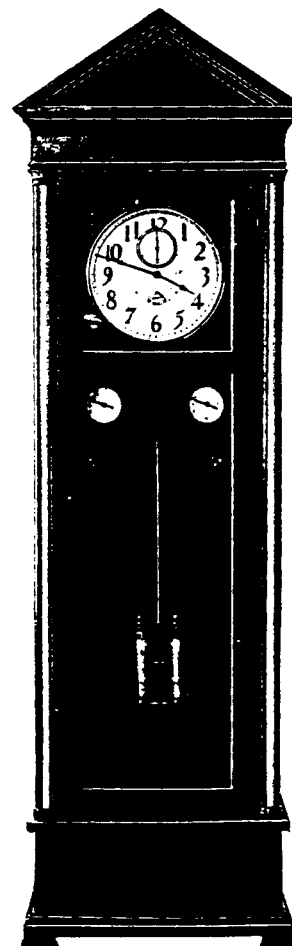

Style F60TD

Special Designs

Specially designed Master Clock cases can be furnished, to order, to meet the requirements of any special installation or to any design as may be submitted.

Landis Electric Clocks (Single Units)

There has been a great demand for a high grade electric self-winding clock for use as a plain regulator. To meet this demand we can offer electric clocks that can be used singly (not a part of a system) for operation from lighting current supply, either 110 volt a-c. or d-c. The clock is wound electrically by connecting to any light socket. Capable of extremely close regulation and can be guaranteed to give excellent satisfaction.

The Landis Electric Clock can be furnished in Style A, B, F, M cases as used for our Master Clocks and are designated as Style A60-110 a-c. or 110 d-c. or 1-volt.

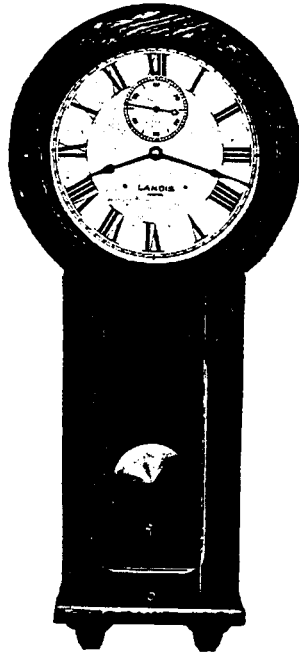

Style "G" 80—12-in. Dial
35x18x5½ in.

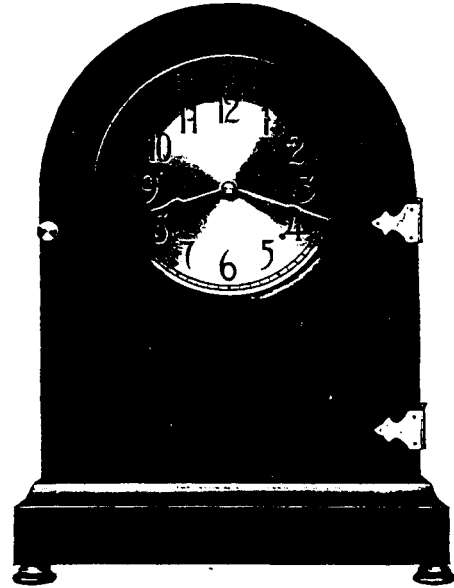

Mantel Clock, 8-in. Dial
18½x13½x5½ in.

The clocks can also be wound electrically by means of a *single* dry cell to supply current for winding. One dry cell will furnish power to wind a clock for a period of from one to three years. A very desirable timepiece where it is not convenient, due to location, to connect to the lighting current supply.

Sturdy Mechanism—The same quality and design of movement as is used in our Master Clocks is used in this single unit electric clock and is not to be considered or confused with some of the delicate electric clocks that have been offered to the real discriminating buyer.

These clocks can be supplied in a great variety of case designs and finishes of either wood or metal. A few designs are shown on this page.

Movements and Dials—Movements can be furnished in either 60, 80 or 120-beat, depending upon size and design of clock desired.

Ordering Instructions—When ordering or specifying the Landis Electric Self-winding Clock, *always specify whether 110 volt a-c. or d-c. supply or dry battery supply.*

Dials of various diameters can be furnished.

Marble dials with bronze numerals and hands are frequently used for public buildings, banks, etc. where a single electric clock is desired.

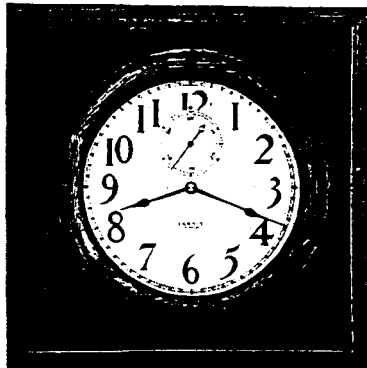

Style "S" 120—12-in. Dial
19x19x5½ in.

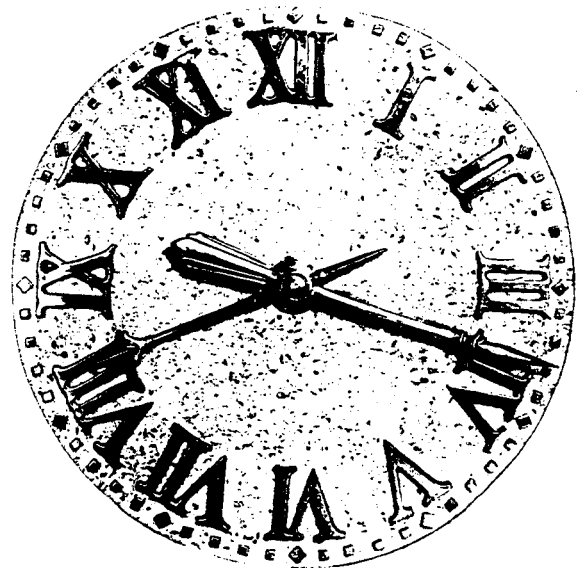

Marble Dial Clocks, 18 to 24 in.
Bronze numerals and hands

Landis Secondary Clocks

Our secondary clocks are controlled automatically through the master clock. Where uniform time is to be indicated at a number of places, there is but one logical method, i. e., use electric secondary clocks.

Secondary clocks have advantages over independent timepieces since they (1) indicate same time as Master Clock; (2) require no regulation, winding, setting or oiling; (3) are not affected by temperature changes or vibration; (4) can be located at points best suited to observation, without reference to their accessibility.

These points are of real concern in a school or building where it is highly essential that accuracy and uniformity of time be shown at all points or locations.

Movement—The Landis Secondary Clock is weight driven, with magnetic control of the driving weight, no springs to set or break, *absolutely non-racing*—a feature not common to other secondary clocks—which insures accuracy and does away with the necessity for elaborate controls for correcting and synchronizing lagging or sluggish moving clocks.

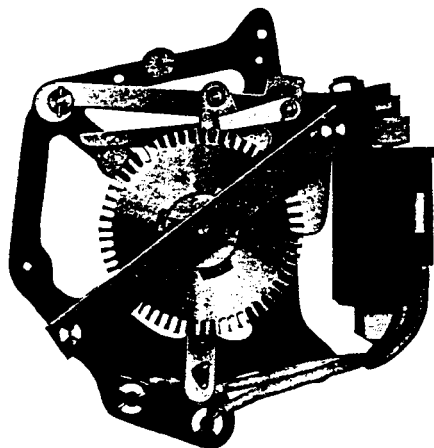

Landis Secondary Clock Movement

The accompanying illustration of the movement of the secondary clock will give an idea of its simplicity and rugged construction. All details are accurately made and so designed that economy and long life are guaranteed to the user.

The movement is absolutely rustless throughout and does not require, in fact it *must not* be oiled.

There is no limit to the number of secondary clocks that can be controlled from one Master Clock.

A simple multiple circuit is used for connecting all outlying secondary clocks to the Master Clock, through a relay which is regularly mounted in Master Clock case.

Styles—Landis Secondary Clocks are regularly furnished in a great variety of cases and finishes, of

either metal or wood; varying sizes of dials from 8 to 36 in., dependent upon the location or size of dial best suited for observation.

Some of the standard styles are shown in accompanying illustrations.

The Style 2M and 2FM cases are the most popular secondary clock cases, made of spun copper, finished in statuary bronze or with duco finish to match color scheme used. 2M being the surface case and 2FM the semi-flush case for mounting over an outlet box set in wall.

The Style 1S and 2 are the general type of wooden cases used, made of oak finished to match wood trim or standard golden oak finish.

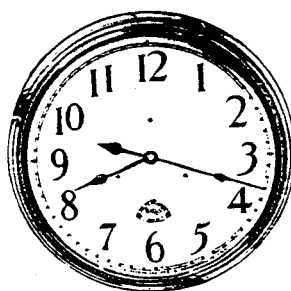

Style 2M
8, 10, 12, 14, 18 and 24-in. dials

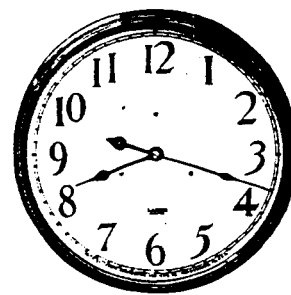

Style 2FM
8, 10, 12, 14 and 18-in. dials



Landis Ceiling Pendant or Sidewall Secondary Clock, Double Face
12, 14, 18 and 24-in. dials

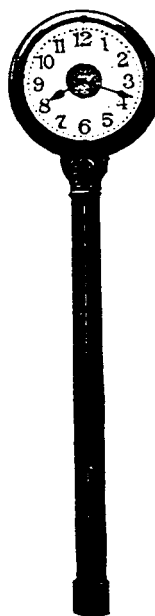

Street Clock
18, 24 and 36-in. double dial illuminated



Marble Dial Clock, 18-24 in.
Bronze hands and numerals

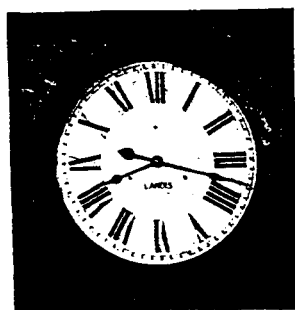

Style 1S
8, 10, 12, 14 and 18-in. dials

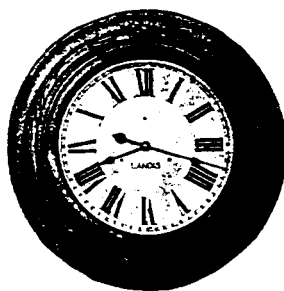

Style 2
8, 10, 12, 14 and 18-in. dials

Tower Clocks

Secondarily controlled movements can be furnished for tower clocks 36 to 60-in. dials, illuminated opalescent dials, with or without striking movements, with or without controls for illumination of dials at night.

Time Stamps

Built of tool steel, strong, durable and compact. The imprinting is a straight line of uniform type read at a glance. It automatically changes the date, hour and meridian.

In addition to the date line, name, address and any wording, such as "Received," "Sent," may be imprinted. These words are changed instantly by turning the square knob at front of stamp.

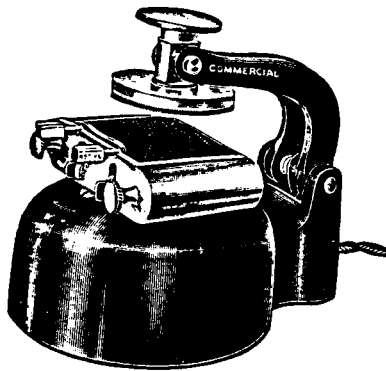

Time Stamp

Time Recorders

In and out time recorders can be furnished for factories, schools and stores, same being synchronized and controlled electrically from the Master Clock insuring uniform time at all recorders throughout a plant.

Cost keeping recorders can also be furnished of various types, similarly synchronized and controlled from Master Clock.

Laboratory Clocks

The accompanying illustration shows a useful accessory for physical laboratories in schools for timing experiments, etc. The dial indicates minutes and seconds and is furnished with or without sounder to give audible second signals. The dial is standard 12-in. dial, regularly furnished in golden quartered oak, or finish to sample.



Laboratory Clock, Style I

Program Machines

The Landis Electric Program Machines are units of an electric time and program clock system that are used for controlling series of signals or operations according to a predetermined schedule. They are made in two distinct types, namely:

(1) The One-minute Interval Program Machine, capable of controlling series of signals or operations at one-minute intervals throughout the day or night.

(2) The Five-minute Interval Program Machine, capable of controlling series of signals or operations at five-minute intervals throughout the day or night.

They are used principally in schools, colleges, factories, etc., to give signals on bells, gongs, or whistles announcing the opening and closing of recitation or study periods, or to give signals for starting and stopping work in factories or department stores.

The Landis Program Machines are also used to actuate relays which operate or control remote control switches for lighting circuits, etc. This provides an automatic control that can be adapted to many uses.

The Landis Electric Program Machines are especially valuable for the *automatic control* of predetermined schedules or programs of signals, due to the following facts:

(1) Number of programs or schedules that can be controlled is unlimited.

(2) The automatic calendar switch cuts *in* or *out* any program on any day or night of the week.

(3) Any program or schedule can be changed throughout, or in any part, by changing the position of contact pins in cylinders and dial, without interfering with the mechanism of the program machine or without the use of special tools.

(4) The length or duration of signal can be adjusted in program machine itself, by means of a knurled nut.

(5) Entirely self-contained, can be operated from any master regulator which has a one-minute circuit closer. All bell ringing contacts are in program machine itself, eliminating bell ringing contacts in Master Clock or regulator as required for many other program machines.

(6) Simplicity of design, rugged construction, gravity drive throughout, with magnetic control of driving weight.

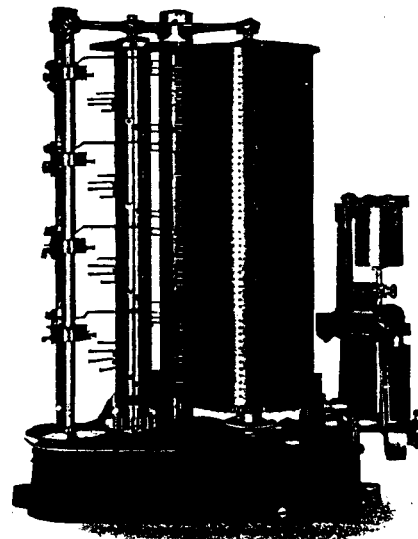

One-minute Interval Program Machine, Four-program

Definitions—By way of explanation of terms used in describing the Landis Electric Program Machines:

A *circuit* is a group of bells or gongs, etc., that is *always* operated or sounded in unison.

A *program* is a 12-hour period: 6:00 A.M. to 6:00 P.M. (the day program), or 6:00 P.M. to 6:00 A.M. (the night program).

How to Select a Program Machine—The most complex schedules for any school, college or factory can be cared for by one of the following methods of program arrangement:

- (1) Each program to control a separate circuit.
- (2) All programs to control the same circuit.
- (3) Groups of programs to control groups of circuits.

The total number of programs necessary being equal to the sum of the number of programs for each circuit.

If signals are wanted only on any minute of the hour divisible by five, a five-minute interval program

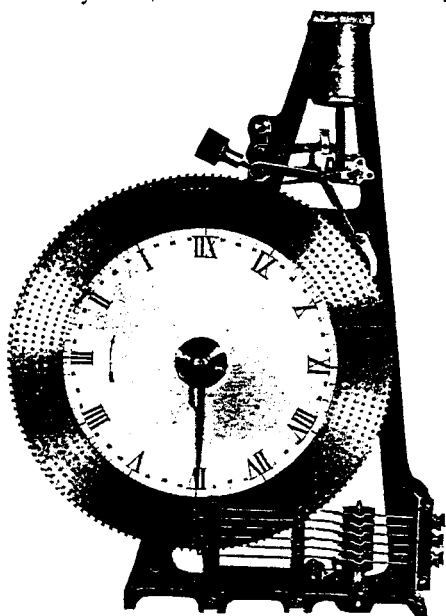

Five-minute Interval Program Machine,
Six-program

machine will meet all requirements. The five-minute interval program machine is made only in six-program size machine.

If, however, a signal is wanted on any minute of the hour, a one-minute interval program machine is required. The one-minute interval program machine is regularly made in three sizes, two, four and six-program units.

There are very few conditions that require more than a six-program unit; additional program machine units can be furnished if requirements call for a greater number of programs.

Program-circuit Selector—By means of the program-circuit selector, with each program machine, it is possible to get any combination of programs and circuits up to the program capacity of the program machine. For example, a six-circuit machine can be so cross connected that (1) all programs will operate on the same circuit, (2) each program on a different circuit, (3) two programs to control one circuit, three programs a circuit, one program a circuit, etc. The program-circuit selector can be rearranged or set in a few minutes, without the use of any tools.

Distributing Board—In many schools it is desirable to have interchangeable bells, i.e., bells that

can be put on any circuit as desired. This is of primary importance in all schools that are liable to have rearrangement of the departments. If a room or group of rooms is to be changed from one department to the other, say from high school to grammar department, the use of the distributing board as shown at top of program machine case (see illustrations on following page) makes it possible to change any bell from one circuit to another without any tools. The change is made by merely changing position of a knurled screw in bell stirrups.

The expense necessary to make changes in wiring would often be prohibitive without the use of distributing board.

A single wire from each bell, with a common wire to the one side of all bells, is brought back to the outlet of the program machine or distributing board. By means of the knurled screw in each bell stirrup (one stirrup for each bell) any bell can be put on any circuit as desired.

With the distributing board on the same case with the program machine, it centralizes the entire bell equipment and simplifies the wiring of building.

Push Buttons—Push buttons are likewise provided on program machine cases and Master Clock cases (when program machine is in same case), for the manual control of bell circuits. Push buttons are very useful for the controls of special schedules, which may make it necessary to depart from the regular set schedules used.

If individual push buttons are desired, one for each bell, buzzer or gong, same can be mounted at top of program machine case.

If, however, individual push buttons are desired when the program machine is mounted in same case with master regulator, the distributing board and push buttons are mounted in a separate case.

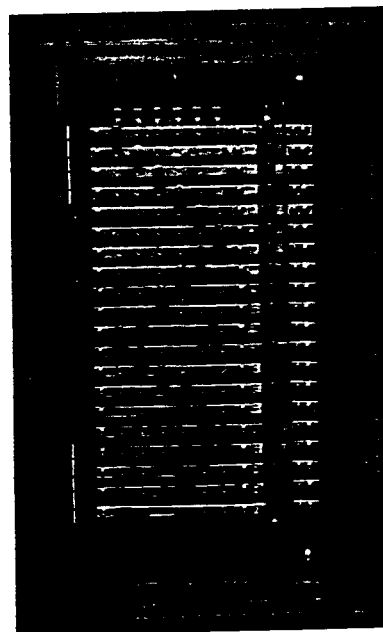

Push Button and Distributing Board in Separate
Case for Wall Mounting

Each individual push button is numbered to give location of bell, buzzer or gong it controls.

The combination of the program-circuit selector and distributing board with the Landis Program Machine makes the most complete program machine equipment that can be desired, as it will meet the most complex and exacting requirements.

Cases for Program Machines

Some of the standard styles of cases in which program machines are mounted are shown on this page, for both the five-minute interval and one-minute interval program machines.

The five-minute interval program machine is always mounted in same case, with the master regulator movement.

The one-minute interval program machine is mounted in a separate case generally, but can be mounted in same case as shown in Style A80T case.

All program machines are furnished with program-circuit selectors, as regular equipment.

The one-minute interval program machine is always furnished with relays, one for each circuit controlled.

Distributing boards are mounted on program machine cases as ordered, with or without push buttons, individual or circuit, of the number of points as required for the installation.

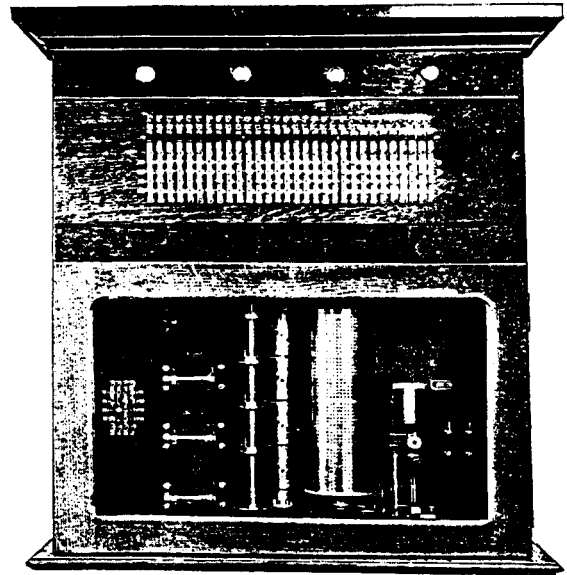

One-minute Interval Program Machine

Four circuits, four-program, program-circuit selector, distributing board individual and circuit push buttons

Finishes—All cabinets are made of wood, generally quartered oak, golden oak finish as standard, special finishes to match wood trim if desired. Special woods and finishes can be furnished to order.

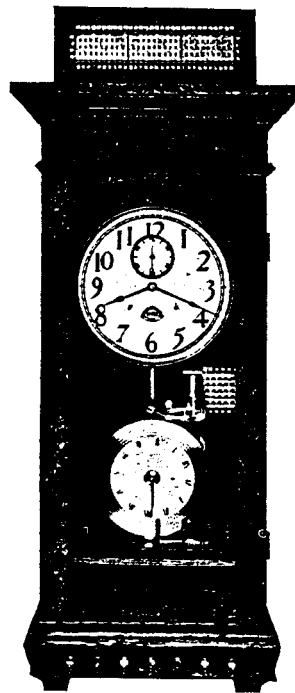

Style B80F Case

With six-program five-minute interval program machine, program-circuit selector, distributing board and circuit push buttons

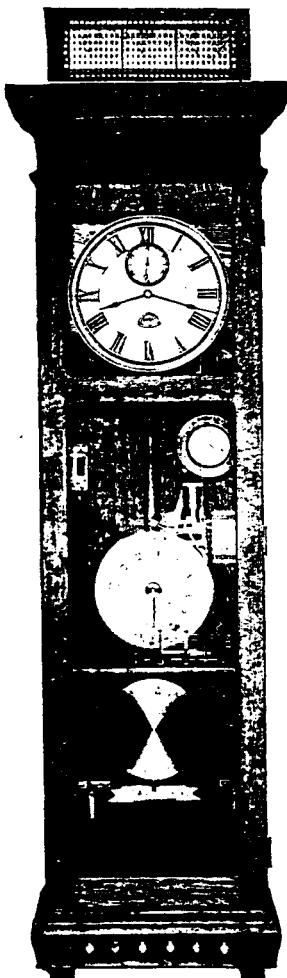

Style A60TF Case

With six-program, five-minute interval program machine, program-circuit selector, distributing board and circuit push buttons

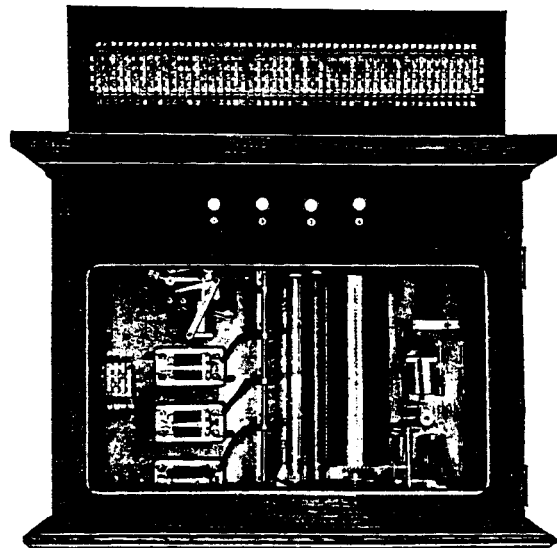

One-minute Interval Program Machine

Four circuits, four-program, program-circuit selector, distributing board and circuit push buttons

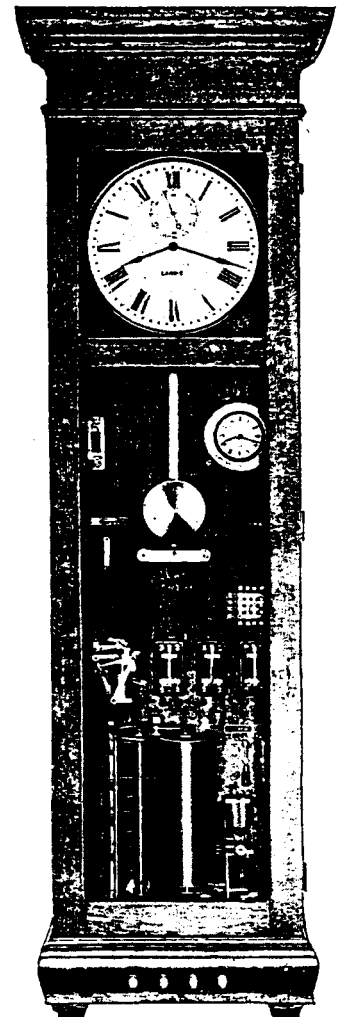

Style A80T Case

With four-program, one-minute interval program machine mounted in same case

Telephone Systems

In a great many schools, telephone systems are desired, but frequently omitted due to cost of installation.

Whenever an individual push button board, as shown in accompanying illustration, is installed in connection with an electric time and program clock system, a very complete yet simple telephone system can likewise be installed.

An outlying room can be signaled through the program bell by pressing the individual button on push button board in the principal's office. The telephone signal being a distinctive signal from the program machine signal (say two short rings). The teacher in outlying room, answering the phone, is in direct communication with main office.

Should teacher in outlying room desire to call the principal's office, by pressing push button on telephone, a separate phone buzzer is operated in the principal's office. Upon the principal removing receiver from wall, the two rooms are in direct communication.

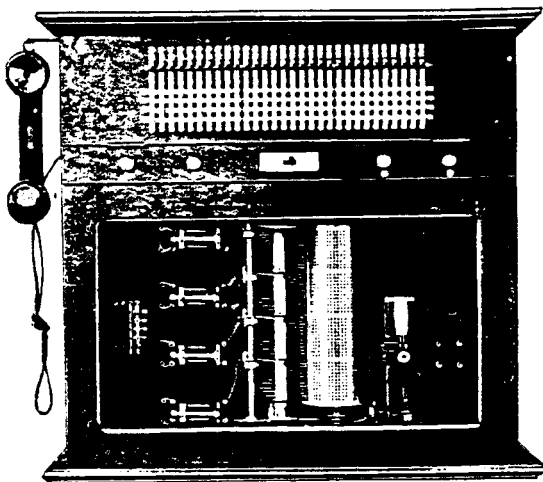

Telephone System with Four-program, Four-circuit, One-minute Interval Program Machine
Has distributing board and individual and circuit push buttons

Phone communication between any two rooms can be secured, but only by calling through the principal's office.

Should more elaborate telephone systems be desired, same can be furnished and used in connection with any Landis Electric Time and Program Clock System.

This type of phone system is very easily installed, as it requires but a single two-wire cable from the principal's office common to each outlying room. The phone system can be operated from the same source of power which operates clock system.

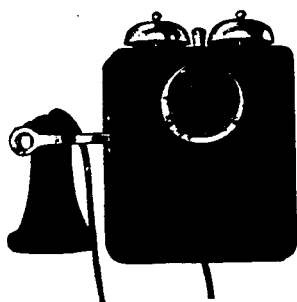

Wall Phone

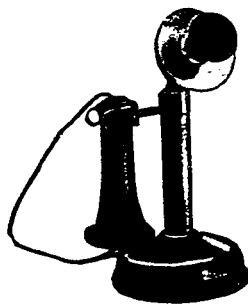

Desk Phone

Fire Alarm Systems

With the use of the Landis Code Ringing Fire Alarm Movement it is possible to add a complete and modern fire alarm equipment to any bell or gong installation as used with a program machine.

This eliminates the necessity for the use of special fire gongs, as the program bells and gongs can be used giving a separate and distinct fire signal on all bells throughout building. If separate fire gongs are desired they can be furnished, either in vibrating or in single stroke type.

With break glass fire alarm stations located throughout a building, the breaking of any glass in these stations will start the Landis Code Ringing Fire Alarm Movement which will sound a distinct code signal such as 3-2 on all bells in the building. The movement repeats code four times, at each alarm. After glass has been replaced at break glass station, the system can be reset at the code ringing fire alarm movement. For fire drills, a test key is provided to turn in an alarm from any break glass station without breaking glass.

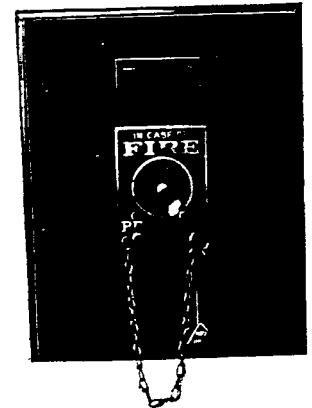

Landis Code Ringing Fire Alarm Station

If the Landis Code Ringing Fire Alarm Movement is not desired, plain break glass fire alarm stations as shown in illustration can be used, which will sound a continuous alarm.

The Landis Code Ringing Fire Alarm Movement can be furnished for each outlying station, with each station to sound a different code, giving exact location of alarm. This type of movement is non-interfering, permitting but one alarm to be turned in at a time. If two glasses are broken, the code alarm is given four times from the first station and then from the second station on completion of the first alarm. The non-interfering code ringing fire alarm can be made for either open or closed circuit systems. Provisions can likewise be made for connecting to any municipal system if desired.

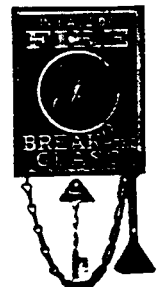

Break Glass Station

Fire Alarm Bells or Horns—For fire alarm systems, a distinctive signal from that of the program bells is sometimes desired. For code ringing fire alarm systems, single stroke bells are recommended. For continuous ringing fire alarm systems, either electric horns or the simultaneous operation of all program bells is recommended.

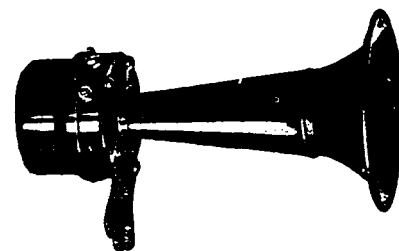

Horn for Fire Alarms and Other Signal Uses, A-C. or D-C. Operated

Relays

When an extra long duration of signal is desired, the Landis Time Element Relay should be used.

This relay is capable of regulation over a wide range, namely from 2 to 50 seconds. By moving counterweight in or out on the upper cam screw, the length of signal can be shortened or lengthened as desired, the position of the counterweight determining the speed at which the piston descends in dashpot, which in turn determines the length of signal.



Landis Time Element Relay

By means of this relay it is possible to have each circuit as controlled by the program machine give a different length of signal, using a Landis Time Element Relay for each circuit to be controlled. These relays are furnished in the following standard voltages, 2, 6, 12, 24 and 30.

All bell and gong circuits, secondary clock circuits, are equipped with Landis Open Circuit Relays, which have carbon and silver contacts, 5-ampere capacity.

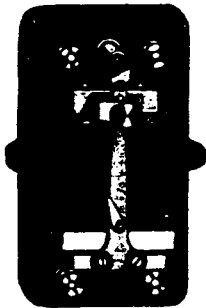

Landis Open Circuit Relay

Relays are furnished in the following standard voltages, 2, 6, 12, 24 and 30.

Carbon contact relays, direct current only, can also be provided for use on open circuit or closed circuit work. The carbon contacts having a capacity of 30 amperes. Magnets are wound for operation from following voltages, 6, 12, 24 and 30.

Time Switches

In connection with electric time and program clock systems, it is often desirable to use a time switch for operating light circuits or motor circuits, according to predetermined schedules. The Landis Time Switch can be used to care for such work.

The Landis Time Switch is regularly furnished in two styles, one-hour cycle and twenty-four-hour cycle, dependent upon requirements of user.

Bells, Gongs, Horns, etc.

It is of utmost importance that the bells, gongs, horns or other signaling equipment for use with an electric time and program clock system or fire alarm system be properly selected.

The size and type of bell, gong or other signaling device depends upon location and kind of service desired.

Resistances—It is of extreme importance that bells and gongs be wound to a resistance suited to the conditions under which they are to be operated. Low resistance bells will not work satisfactorily where a large number of bells are to be used, if economical results are to be secured.

BELL RESISTANCES IN OHMS

Size of bell	6 volts	12 volts	24 volts	30 volts
Buzzers, 2 1/2, 3, 4,	30	120	480	750
6, 8, 10 and 12	20	75	300	450
in.	8	30	120	130

The illustrations show typical bells, buzzers, gongs such as are recommended for use at various locations dependent upon service required.

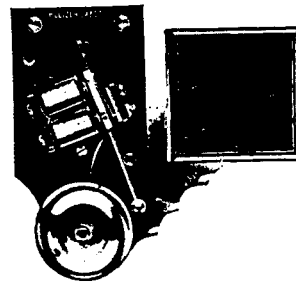

Wood Box Bell with Cover Removed



Corridor Gong

Adaptability—Classrooms: buzzers; 2 1/2 and 3-in. bells.

Large rooms and corridors: 4 and 6-in. bells.

Outside gongs: 8, 10 and 12-in. waterproof gongs.

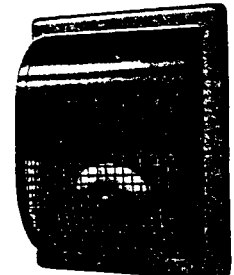

Weatherproof Gong

Transformer Bells and Gongs

Where an a-c. power unit is used for the operation of a complete system it is very desirable to use a separate transformer for operating bell and gong equipment, particularly where a large number of bells and gongs is used.

The transformer bell has been developed to make it possible to operate large gongs on low voltage alternating current.

Standard windings run from 6 to 24 volts a-c. 60 cycles; they can, however, be furnished to operate at 25 to 40 cycles. Windings can be provided for 110 volt 60 cycles a-c.

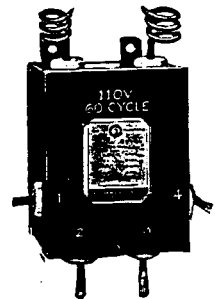

Transformer

Transformers

The selection of a proper capacity transformer is quite essential where a number of bells are to be operated simultaneously. Many transformers are rated at higher capacity than they deliver.

The input wattage should not be confused with the output wattage in determining the correct wattage for the transformer to be used.

A safe rule to follow in determining the correct wattage for a transformer is as follows:

The sum of the total number of inches in diameters of all gongs to be operated simultaneously, multiplied by 2, equals wattage required.

This will insure the selection of a transformer of adequate capacity as well as provide for secondary line losses in long runs of wiring.

Practically all transformers have several secondary voltage taps. The voltage should be selected that operates bells best for each size of transformer.

Standard wattages for transformers are: 50, 75, 100, 125, 250 and 500.

In ordering or specifying transformers, always specify voltage and number of cycles of a-c. supply.

Battery Charging Equipment, Alternating-current Power Units

The question of battery equipment or power for an Electric Time and Program Clock System, is quite an important consideration.

Primary battery was the chief source of power supply for the early Electric Time and Program Clock Systems. This source of power is no longer used, only where lighting current supply is not available.

With practically the entire country so completely covered by electric power lines, we can now use some of the more modern and less expensive sources of power for an Electric Time and Program Clock System.

Storage Batteries—The storage battery furnishes the most dependable source of power. A factor of safety is offered with a storage battery that precludes the possibility of current interruptions interfering with constant power supply for a system.

It is, however, quite essential to select and use a storage battery that is properly designed and of such capacity that it will adequately handle the system.

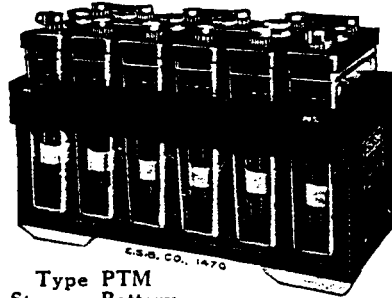

Type PTM
Storage Battery

We recommend the use of two standard voltages for all electric time and program clock systems, namely, 12 volts and 24 volts. The storage batteries being of the following capacities:

Type CTM.....12-ampere hours
Type PTM.....24-ampere hours

The number of units used with a system determines the voltage and ampere hour capacity of the storage battery to be used.

Battery Charging Equipment—The proper selection of storage battery charging equipment is likewise quite essential for satisfactory operation of an electric time and program clock system,

Two standard types of automatic battery charging equipment are recommended, namely, Type A and Type PR.

The Type A Landis Automatic Charging Panel keeps the battery operating under best conditions, automatically charging battery *when* required, and at the same time providing full protection to the system against current interruptions and overloads.

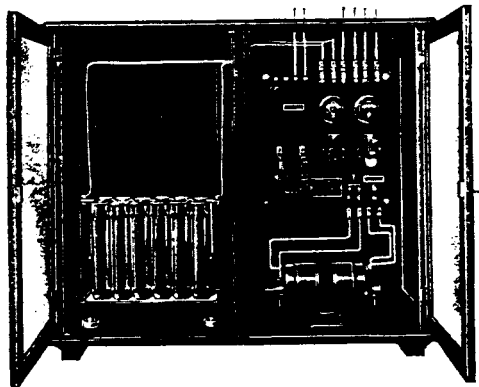

Type A—Landis Automatic Charging Panel

With motor generator and storage battery all mounted in one cabinet

The Type A Landis Automatic Charging Panel consists of a 7/8-in. slate panel 17x21 in. with following equipment mounted on same:

- 1 Landis Automatic Time Switch.
- 1 High Voltage Relay.
- 1 Voltmeter.
- 1 Ammeter.
- 1 2-pole Magnetic Switch.
- 1 Reverse Current Relay.
- 1 Pick-up Relay.

Necessary knife switches, fuses and terminals.

Once each hour, the Landis Automatic Time Switch throws the panel into service to charge the battery. If the voltage of the battery is below standard, a charge is given the battery for the period of time as set on the time switch. If battery voltage is up to standard, the high voltage relay opens, refusing the charge. By means of a pick-up contact on the magnetic switch, the battery is given an occasional over-charge.

The Type A charging panel is to be recommended for all larger installations of electric time and program clock systems and where a *quality* installation is desired against one that might be offered on a purely competitive price basis.

As a competitive automatic charging panel, the Type PR panel is offered.

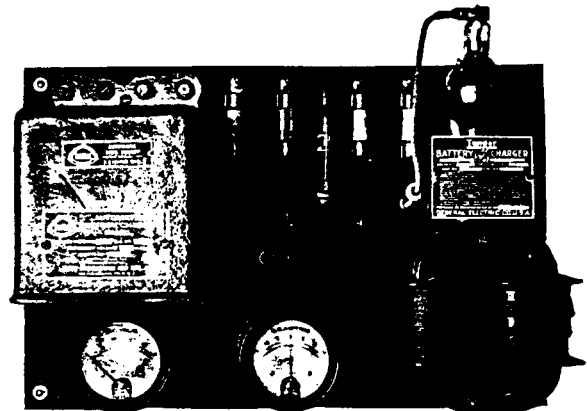

Type PR Landis Automatic Charging Panel

The Landis Automatic Charging Panel, Type PR, places the battery on charge once each hour for a predetermined time as set upon the Landis Automatic Time Switch, the amount of each charge being sufficient to restore the energy used for the operation of the system.

This panel uses a rectifier unit for charging the storage batteries.

Both Type A and Type PR Panels can be furnished in steel cabinets.

Alternating-current Power Units—Some installations may desire to connect directly to the power supply without the storage battery, as a factor of safety. In this event, we can provide an alternating-current power unit, consisting of a dry plate rectifier and transformer of proper capacity to operate the system from an alternating-current supply of the voltage and number of cycles used.

If direct-current supply is available, a resistance unit can be provided of proper capacity to provide for the satisfactory operation of system.

All alternating and direct-current units can be mounted on slate panels and enclosed in steel cabinets, if desired.

SPECIFICATIONS FOR ELECTRIC TIME AND PROGRAM CLOCK SYSTEMS

(1) Furnish and install a Landis Electric Clock System in accordance with the following specifications, as manufactured by the LANDIS ENGINEERING AND MFG. CO., Waynesboro, Pa.

(2) The installation of the conduit and wiring shall be made by the electrical contractor in accordance with detailed conduit and wiring layout as provided by the manufacturer. The connection of the electric clock system to wiring shall be made by the manufacturers or under their direction.

Master Clock or Regulator—

(3) Provide one Landis Self-winding Regulator 60 [80] beat with 12-in. white enameled dial, with wooden rod and metal bob pendulum [mercurial compensating pendulum] with Graham dead beat escapement, accurately cut gearing, steel pinions, hardened burnished pivots, and hard brass pivot bushings, capable of regulation to within 30 seconds per month (if mercurial compensating pendulum 10 seconds per month).

(4) Movement shall be weight driven, with maintaining power spring, to provide constant driving power at all times.

(5) Winding contacts shall be non-adjustable and quick-breaking, so designed that magnets of winding mechanism are only energized the exact length of time necessary to wind the clock. Winding contact shall not be made more than once every 5 minutes and of not more than one-tenth second duration.

(6) Movement shall be provided with platinum tipped circuit closer for the operation of all secondarily operated equipment. Circuit closer shall be so designed that length of contact is independent of swing of pendulum. Making point of circuit closer shall be at a different point than breaking point with contact made by positive wiping motion across platinum contacts.

(7) All switches, pilot clocks, relays, etc., necessary for the control of secondarily operated equipment shall be mounted in same case with master regulator movement.

(8) Master regulator movement shall be mounted in a hanging wall type case, golden quartered oak cabinet finish [finish to match adjacent wood trim].

Program Machine—

(9) Provide one Landis Automatic Universal Program Machine to operate at 1- [5-] minute intervals, capable of control of (give number of programs) of 12 hours each.

(10) Provide one program-circuit selector, so that any or all programs or circuits can be tied together or cross-connected as desired.

(11) The program machine shall be provided with an automatic calendar switch to automatically cut in or out any program on any day or night of the week, according to a predetermined schedule. The time of signals on any day, hour and minute shall be quickly changed by positions of pins in dial or cylinder and calendar switch. The length of signal shall be capable of quick regulation of bell ringing circuit closer on program machine without the use of tools or instruments.

(12) The 1- [5-] minute interval program machine shall be mounted either in same case with master regulator or separate wall case.

Note: 1-minute interval program machines are generally mounted in separate wall cases.

(13) Program machine case shall be finished to match finish of master clock case.

Time Element Relay—

(14) Provide one Landis Time Element Relay for control of outside gongs where it is desirable to have a longer signal than that of inside bells or gongs.

Bells, Buzzers and Gongs—

(15) Provide bells, buzzers and gongs for various rooms, corridors and outside locations (as per schedule).

Note: Buzzers and 2½-in. bells used in general for classrooms, 6-in. gongs for corridors, 8 and 10-in. weatherproof gongs for outside. All bells, buzzers and gongs shall have a high resistance winding.

Distributing Board—

(16) Provide one distributing board with points, as many points as there are bells and gongs, with busbars, one for each bell or gong circuit. Means shall be provided to put any bell or gong on any circuit as desired without the use of tools or instruments.

(17) Distributing board shall be mounted on

Note: If used with a 1-minute program machine, distributing board is mounted on program machine case. If used with a 5-minute program machine, on master clock case.

Push Button Board—

(18) Provide a push button board of points, by means of which any or all bells can be controlled, dependent upon the following schedule:

Note: If individual bells are to be manually controlled, one individual button for each bell. If bell circuits are to be controlled, one circuit button for each bell circuit. If all bells are to be controlled simultaneously, one simultaneous button.

(19) The push button board shall be mounted on

Note: If used with 1-minute interval program machine, to be mounted on program machine case. If used with 5-minute interval program machine, on master regulator case, when only circuit buttons and simultaneous buttons are used. If individual buttons are used with circuit and simultaneous buttons, distributing board and push button board are mounted in separate wall case, or on 1-minute interval program machine case.

Telephones—

(20) Provide wall, surface type [flush type] telephones for various rooms or offices as desired. Telephones to be equipped with long type bi-polar receivers. Finish of all phones to be dull black.

Note: Desk sets can be used for offices if desired.

Master Phone—

(21) Provide at location of push button board, one hand set phone, with talking key in handle of bi-polar receiver.

(22) Provide on push button board for Central Station Telephone equipment, one telephone relay; one buzzer for indicating incoming calls and also for use as a clearout signal; one two-position listening key.

Telephone Wiring—

(23) Provide one common talking circuit to all outlying stations, consisting of two No. 14 rubber covered wires, terminating at master phone station or location of push button board.

Secondary Clocks—

(24) Provide secondary clocks, Landis Electric Type, of style, size of dial and at locations as follows:

Note: Here indicate number of clocks, size of dial (8-in., 10-in., 12-in., 14-in. or 18-in.), Style (1S square wood, 2-round wood, 2M round metal surface type, 2FM round metal flush type).

(25) All secondary clocks shall be equipped with movements constructed without springs, gravity actuated, magnetically controlled. The movement shall be positively locked at all times, before, during and after impulse from master regulator. All gearing of movement shall be accurately cut from hard rolled brass, all parts of steel and brass shall be either copper-plated or nickelplated, movement shall be rustless, shall not require oiling and shall be mounted on an enameled base.

(26) Each secondary clock dial with its movement shall represent a complete unit, same to be mounted in dustproof case by means of bayonet lock switch, so that any dial and its movement can be quickly removed from wall without the use of any tools.

(27) Secondary clock cases shall be made of quartered oak [golden oak] cabinet finish [finish to match wood trim]. Or metal cases [spun copper] [finished statuary bronze] [special finish].

Fire Alarm System—

(28) Provide a complete fire alarm system in connection with above system of bells and gongs, to be operated and controlled by means of break glass fire alarm stations, with test keys which shall be located throughout building at stations as directed. Break glass fire alarm stations to control Landis Electric Self-winding Code Ringing Fire Alarm Movement which shall sound 4 distinct fire signals, such as a 3-2 on all bells and gongs, differing from program signal, yet permitting use of same bells and gongs used for program purposes.

Note: Systems can be made either open or closed circuit as desired.

Battery—

(29) Provide a complete storage battery of ample capacity to operate entire equipment, consisting of cells chloride accumulator type

Note: For systems up to and including 25 clocks and bells, specify 6 cells Type CTM; up to and including 60 clocks and bells, specify 6 cells Type PTM; above 60 clocks and bells, specify 12 cells Type PTM. For systems covering a number of buildings as over a campus, consult manufacturer.

Battery Charging Equipment—

(30) Provide one Landis automatic charging panel for keeping storage battery fully charged at all times.

Note: Same can be furnished in two styles, Type A, the full automatic supervised panel with motor generator set, or the Type PR with rectifier unit mounted on panel. Both panels, Type A and PR, can be furnished in steel cabinet if desired.

Alternating-current Power Supply—

(31) If storage batteries are to be eliminated, an alternating current power unit can be substituted.

(32) Provide one alternating current power unit, consisting of dry plate rectifier and transformer of proper capacity to operate system from 110-volt a-c. 60-cycle supply.

(33) This equipment to be mounted on slate panel and enclosed in steel cabinet.

Wiring—

(34) All wiring shall be rubber covered and braided fixture wire not smaller than No. 16 B&S gauge for all interior wiring

and shall be installed in strict accordance with rules of National Board of Fire Underwriters.

(35) All conduit and wiring to be installed as per conduit and wiring layout and specifications as furnished by manufacturer.

Guarantee—

(36) All materials provided as above specified shall be

guaranteed against all original mechanical and electrical defects for a period of one year from date of completion of said installation. The condition of this guarantee is such, that if at any time within the term of guarantee any part of the mechanism is altered or repaired by any other than the manufacturers or their duly authorized representatives, their liability under this guarantee shall cease.

SPECIFICATION FOR SIMPLE PROGRAM SYSTEM FOR SMALL SCHOOLS USING ONLY SIGNAL EQUIPMENT

General—

(1) Furnish and install a Landis Electric Program Clock System in accordance with the following specifications, as manufactured by the LANDIS ENGINEERING AND MFG. CO., Waynesboro, Pa.

(2) The installation of the conduit and wiring shall be made by the electrical contractor in accordance with detailed conduit and wiring layout as provided by the manufacturer. The connection of the electric program clock system shall be made by the manufacturers or under their direction.

(3) The following equipment shall be furnished in connection with this system:

1 Master clock	6 Circuit push buttons
1 Program machine	2½-in. bells for classrooms
1 Time element relay	6-in. gongs for corridors
1 Distributing board	10-in. gongs for outside
1 A-c. power unit	

Master Clock or Regulator—

(4) Provide one Landis Self-winding Regulator, 80-beat with 12-in. white enameled dial, with wooden rod and metal bob pendulum, Graham dead beat escapement, accurately cut gearing, steel pinions, hardened burnished pivots and hard brass pivot bushings, capable of regulation to within 30 seconds per month.

(5) Movement shall be weight driven, with maintaining power spring to provide constant driving power at all times.

(6) Winding contacts shall be non-adjustable and quick breaking, so designed that magnets of winding mechanism are only energized the exact length of time necessary to wind the clock. Winding contact shall not be made more than once every five minutes and more than one-tenth second duration.

(7) Master regulator movement shall be mounted in a hanging wall type case, golden quartered oak cabinet finish [finish to match adjacent wood trim].

Program Machine—

(8) Provide one Landis Automatic Program Machine of the five-minute interval dial type, capable of control of 6 programs of 12 hours each, on 6 circuits, with a program-circuit selector so that any or all programs or circuits may be tied together or cross-connected as desired.

(9) Program machine shall be provided with an automatic calendar switch to automatically cut in or out any program on any day or night of the week, according to a predetermined schedule. The time of signals on any day, hour or five minute period shall be quickly changed by position of pins in dial and calendar switch.

(10) The length of signal shall be capable of quick regulation of bell ringing circuit closer on program machine without use of tools or instruments.

Installation Data

With detailed specifications (as per the foregoing), conduit and wiring layouts and wiring diagrams (as shown on the following pages), the electrical contractor can install all conduit and wiring whilst building is in course of erection.

Accompanying each conduit and wiring layout, complete detailed specifications are given to the electrical contractor, as to the different sizes of outlet boxes to be used at the various locations, such as for—Master Clock, Program Machine, Fire Alarm Stations, Telephones, Secondary Clocks, Bells, Gongs, Battery, Charging Equipment, etc.

Complete instructions are also given as to the pulling of wires into conduit, splicing of wires, testing of wiring and finally the proper tagging of all wires that terminate in the various outlet boxes.

With complete specifications and instructions covering all details of the installation of conduit, outlet boxes and wiring, there should be no trouble experienced by any electrical contractor in doing his work.

The installation of the equipment can be made by our installation men or under our supervision or direction.

(11) The five-minute interval program machine shall be mounted in same case with the master regulator.

Time Element Relay—

(12) Provide one Landis Time Element Relay for control of outside gongs where it is desirable to have a longer signal than that of inside bells or gongs. This time element relay shall be mounted in the master clock case.

Distributing Board—

(13) Provide a distributing board, with . . . points, as many points as there are bells and gongs, with 6 busbars, one for each bell or gong circuit. Means shall be provided to put any bell, buzzer or gong on any circuit as desired without the use of tools or instruments. Distributing board shall be mounted on top of master clock case.

Push Buttons—

(14) Provide 6 circuit push buttons, one for each circuit in program machine for manual control of all bells, buzzers or gongs for special signals. These push buttons shall be mounted on the bottom of master clock case.

Bells and Gongs—

(15) Provide bells, buzzers and gongs for various rooms, corridors and outside locations (as per schedule).

Note: Buzzers and 2½-in. bells are used in general for classrooms, 6-in. gongs for corridors, 8 and 10-in. weatherproof gongs for outside. Outside gongs to be provided with housing, mat and screen if desired. All bells, buzzers and gongs shall have a high resistance winding.

A-c. Power Unit—

(16) Provide Alternating-current power unit consisting of dry plate rectifier and transformer of proper capacity to operate entire system direct from 110-volt 60-cycle a-c. supply.

(17) This equipment to be mounted on slate panel and enclosed in steel cabinet.

Wiring—

(18) All wiring shall be rubber covered and braided fixture wire not smaller than No. 16 B&S gauge for all interior wiring and shall be installed in strict accordance with the rules of the National Board of Fire Underwriters.

(19) All wiring to be installed in accordance with the wiring diagrams as furnished by the manufacturer.

Guarantee—

(20) All materials provided as above specified shall be guaranteed against all original mechanical and electrical defects for a period of one year from date of completion of said installation. The condition of this guarantee is such, that if at any time within the term of this guarantee, any part of the mechanism is altered or repaired by any other than the manufacturers or their duly authorized representatives, their liability under this guarantee shall cease.

Landis Engineering Service

The foregoing detailed specifications can serve as a guide for the preparation of specifications by the Architect or Engineer for each particular installation.

No matter how complicated the problems may be our engineers are at your service to assist in the layout of equipment suited to your particular problems.

In order to insure an adequate and complete electric time and program clock system to meet your requirements, send us a copy of your floor plans with an elevation, to permit us to prepare a complete conduit and wiring layout, with complete detailed specifications, same to be incorporated with your electrical specifications. We make no charge for this service, and we will gladly give Architects and Engineers any information pertinent to our line that they may request.

Landis Service Contracts

Our service men are available at all times to see that our systems give satisfaction.

We can offer each user a special *service contract* to keep all installations under our constant supervision, providing for periodic inspections by our service men. The cost of this service is very nominal, dependent upon our actual cost.

Landis Users

Our installations number in the thousands throughout the civilized world and are likewise found in every state in United States. Some typical installations follow:

A Few Public Schools Using Landis Equipment, Located in the Following Cities

- Philadelphia, Pa.
- Los Angeles, Calif.
- Baltimore, Md.
- Butte, Mont.
- Louisville, Ky.
- El Paso, Tex.
- Winnipeg, Canada
- Phoenix, Ariz.
- Chicago, Ill.
- Atlantic City, N. J.
- Altoona, Pa.
- St. Maries, Ida.
- Bluffton, Ind.
- Elizabeth, N. J.
- South Bend, Ind.
- Durham, N. C.
- Coshocton, Ohio
- Fort Lauderdale, Fla.
- Harrisburg, Pa.
- Snow Hill, N. C.
- Shamokin, Pa.
- Carlisle, Pa.
- Houston, Tex.
- Salt Lake City, Utah
- Winchester, Va.
- Beloit, Wis.
- Detroit, Mich.
- Kirksville, Mo.
- Marion, Ind.
- St. Louis, Mo.
- Grosse Pointe, Mich.
- Brownsville, Tex.
- Stroudsburg, Pa.
- Fort Wayne, Ind.

A Few Colleges and Schools Using Landis Equipment

- University of Oklahoma, Norman, Okla.
- Pennsylvania State Forestry School, Mont Alto, Pa.
- Asheville School, Asheville, N. C.
- Penn Hall, Chambersburg, Pa.
- New Mexico School of Mines, Socorro, N. M.
- Findlay College, Findlay, Ohio
- Hackley School, Tarrytown, N. Y.
- Junior College, Augusta, Ga.
- State Teachers College, Harrisonburg, Va.
- Colegio de La Salle, Havana, Cuba
- University of Toledo, Toledo, Ohio
- Arkansas College, Batesville, Ark.
- Hotchkiss School, Lakeville, Conn.
- School for Deaf and Blind, Colorado Springs, Colo.
- National Cathedral School, Washington, D. C.
- U. S. Naval Academy, Annapolis, Md.
- Masonic Home School, Franklin, Ind.
- University of Kentucky, Lexington, Ky.
- Louisiana Polytechnic Institute, Ruston, La.
- Western Maryland College, Westminster, Md.
- Columbia College, Columbia, S. C.
- State Normal School, Johnson City, Tenn.
- Hill School, Pottstown, Pa.
- Pennington School, Pennington, N. J.
- Mercersburg Academy, Mercersburg, Pa.
- State Normal School, Morehead, Ky.
- Eastern Illinois State Teachers College, Charleston, Ill.
- State Normal School, Silver City, N. M.

A Few Public Buildings, Using Landis Equipment

- Federal Penitentiary, Leavenworth, Kan.
- Parliament Buildings, Ottawa, Canada
- Bureau of Terrestrial Magnetism, Washington, D. C.
- Bureau of Terrestrial Magnetism, Hunancaya, Peru
- Bureau of Terrestrial Magnetism, Watheroo, West. Australia
- Commonwealth Solar Observatory, Canberra, New South Wales
- Y. M. C. A., Indianapolis, Ind.
- Citizens Savings Bank & Trust Co., Marion, Ind.
- Riverside County Courthouse, Riverside, Calif.
- Fort Shelby Hotel, Detroit, Mich.
- Franklin County Courthouse, Chambersburg, Pa.
- Cooper Branch Free Library, Camden, N. J.
- Municipal Court Building, Grosse Pointe, Mich.
- State Sanatorium, Mont Alto, Pa.
- Burleson County Courthouse, Caldwell, Tex.
- Harper Hospital, Detroit, Mich.
- Wayne County and Home Savings Bank, Detroit, Mich.

A Few Industrial Plants Using Landis Equipment

- National Carbon Co., Cleveland, Ohio
- Bell Telephone Laboratories, New York, N. Y.
- Detroit Edison Co., Detroit, Mich.
- Jos. Bancroft Sons Co., Wilmington, Del.
- Garlock Packing Co., Palmyra, N. Y.
- Detroit Street Railway Co., Detroit, Mich.
- Minneapolis Heat Regulator Co., Minneapolis, Minn.
- D. Landreth Seed Co., Bristol, Pa.
- Burroughs Adding Machine Co., Detroit, Mich.
- W. H. Reiser Mfg. Co., Hagerstown, Md.
- Diamond State Brick Co., Wilmington, Del.
- Ternes Coal & Lumber Co., Detroit, Mich.

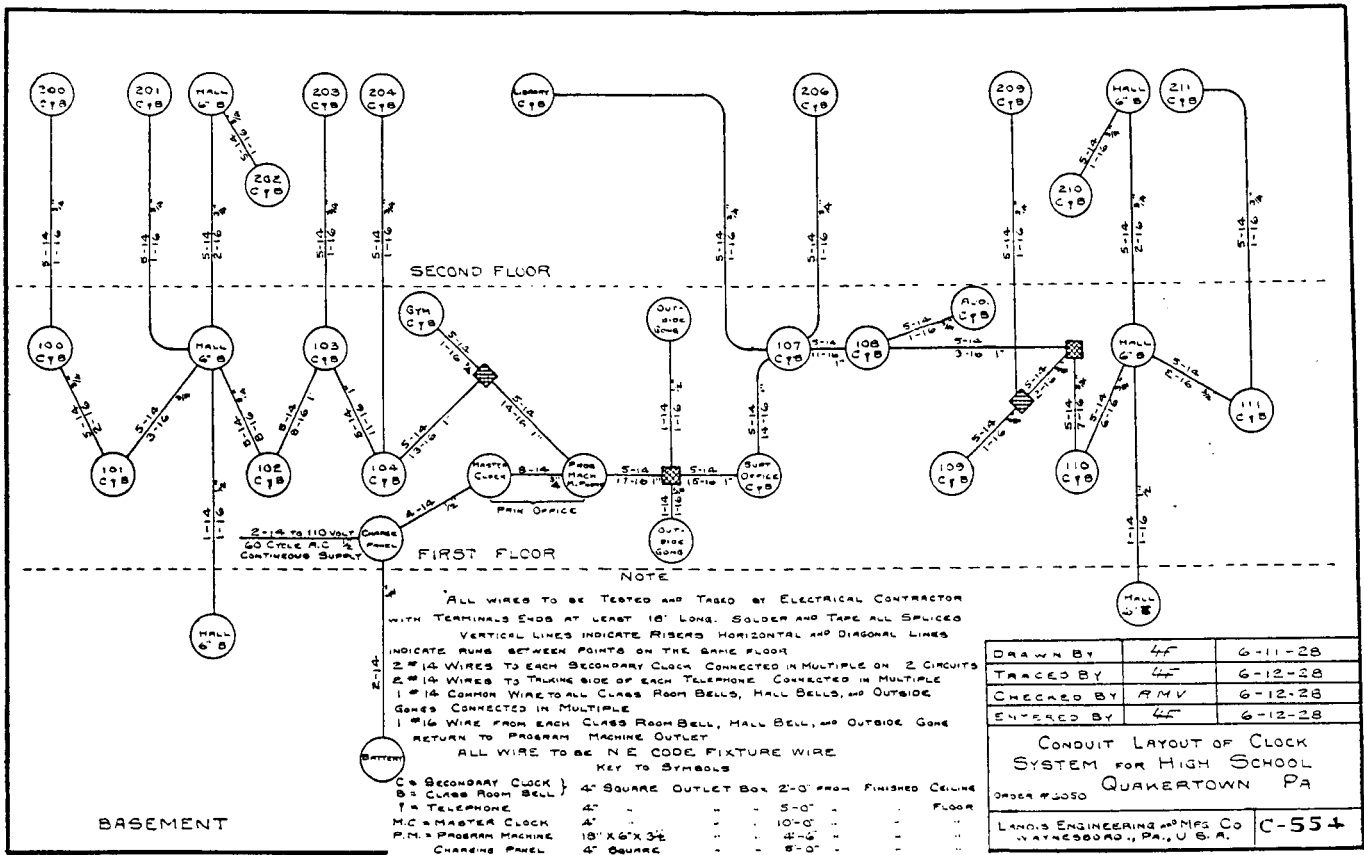

Landis Emergency Lighting System

Purpose—Legislation in many States has compelled theaters, auditoriums, stores and all places where a number of people are assembled after dark, to provide emergency lighting systems for public safety, in case of failure of the regular lighting current supply.

Demands Upon a System—In the event of failure of the regular lighting current supply, provision is made to automatically throw into service an emergency source of power, connecting to separate and distinct emergency lighting circuits.

Upon the restoration of the main current supply, the emergency lighting system must instantly and automatically disconnect the emergency lighting circuits from the storage battery.

The storage battery must have an ampere hour rating sufficient to carry the entire emergency light load for a period of at least one and one-half hours.

The wattage of the emergency lights must provide for a minimum of twenty-five one hundredths of a foot candle on the floors of all auditoriums, hallways, corridors and passageways and five-tenths of a foot candle on the floor at all exit doors.

Upon the failure of the main lighting supply and the impressing of the emergency lighting supply into service, the storage battery must be capable of being fully recharged within 12 hours, even in the event of a complete discharge of the storage battery.

The battery charging equipment must be capable

Disadvantages of Some Emergency Lighting Systems—(1) Failure to keep storage battery properly charged.

(2) The use of the unsatisfactory "trickle" charge.

(3) The failure to provide adequate supervisory signals.

(4) The use of storage batteries of too small capacity.

(5) The use of charging units of inadequate rating.

(6) The sacrifice of quality to get a low sales price.

Advantages of the Landis Emergency Lighting Systems—(1) A quality product that insures economy and satisfactory service.

(2) Control panel design most complete in all details for the operation of the system.

(3) Audible and visual supervision of system to indicate trouble of any kind.

(4) Automatic charging for storage battery when required.

(5) The use of a 12-hour normal charge rate, as a minimum charge rate.

(6) The use of storage batteries of ample capacity for duty required.

(7) The use of an electric clock or a complete electric clock system to keep the battery active, and control the supervision of system.

Landis Automatic Charging of Storage Battery—By means of the same principles that are used in the Landis Automatic Charging Panel, which is used as a regular equipment in our electric time and program clock systems, we can maintain the voltage of the storage battery for the emergency lighting system and secure maximum operating efficiency. The time element for charging storage battery is supplied by the Landis Self-winding Regulator, as shown at the top of control panel or by the combination of an emergency lighting system with an electric time and program clock system, the storage battery being used common to both systems.

With the load of the clock system placed upon the storage battery, it is kept active instead of lying dormant most of the time, as is the case with a storage battery used for an emergency lighting system only.

The Type AEG Control Panel is regularly made in three sizes, 30 ampere, 60 ampere and 100 ampere.

All AEG Control Panels are of same size, namely, 21x40 in.

All AEG Panels use motor-generator sets for charging storage batteries.

See table on following page for complete specifications.

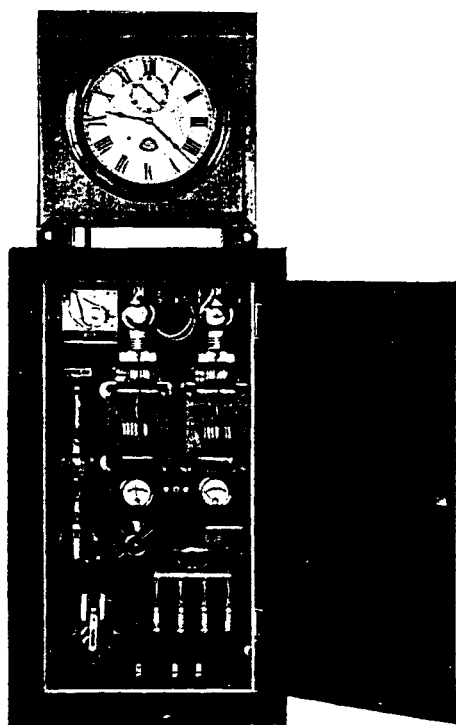

Type PER Control Panel in Steel Cabinet

of keeping the battery fully charged at all times, to absolutely guarantee the storage battery being up to normal voltage and in condition to give service when called upon.

The Type PER Control Panel is regularly made in two sizes, 30 ampere and 60 ampere.

Type PER—30-ampere Control Panel is 24x30 in.

Type PER—60-ampere Control Panel is 21x40 in.

See table on following page for complete specifications.

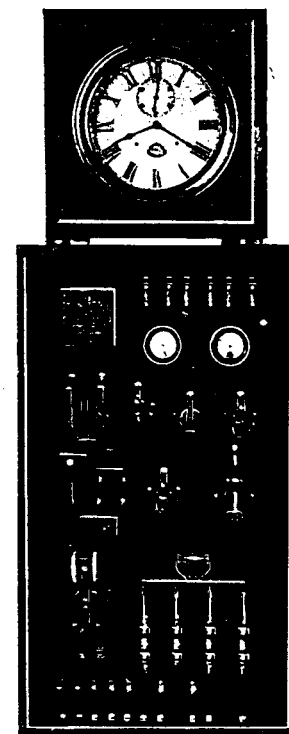

Type AEG Control Panel
With front and door removed
from steel cabinet

Voltages and Types of Landis Emergency Lighting Systems

We manufacture systems of two standard voltages, namely, 32 and 110 volts, of the wattage ratings for each as given in the accompanying tables. The tables show the specifications of storage battery recommended for the normal wattage of the system to be used; the type of control panel and ampere rating of same; the type of charging unit used for each wattage, and, if a motor-generator set is used, the voltage and wattage of same.

32-VOLT SYSTEMS

Wattage			Storage Battery Specifications					Control Panel		Motor-Generator Sets	
Normal	Maximum	Minimum	Type	Ampere hour capacity 8 hr.	Ampere discharge rate 1.5 hr.	Ampere charge rate		Type	Ampere rating	Voltage	Watts
						8 hr.	12 hr.				
350	368	304	PTO-3	24	11.5	3.	2.	PER	30	Tungar rectifier units made a part of PER control panels	
500	512	425	KXF-5	34	16.	4.25	2.83	PER	30		
750	768	635	KXF-7	51	24.	6.4	4.27	PER	30		
1000	1024	845	KXF-9	68	32.	8.5	5.65	PER	60		
1250	1280	1055	KXF-11	85	40.	10.63	7.07	AEG	60	36	350
1500	1532	1268	KXF-13	102	48.	12.75	8.5	AEG	60	36	350
1750	1792	1480	KXF-15	119	56.	14.9	10.	AEG	60	36	350
2000	2048	1690	KXF-17	136	64.	17.	11.3	AEG	60	36	500
2400	2432	2000	KXF-19	153	76.	19.15	12.75	AEG	100	36	500
2800	2816	2320	KXF-21	170	88.	21.2	14.15	AEG	100	36	500

110-VOLT SYSTEMS

375	385	334	BTO-3	6	3.5	.75	.5	PER	30	Tungar Rectifier units made a part of PER control panels	
750	770	668	CTO-3	12	7.	1.5	1.	PER	30		
1250	1265	1095	PTO-3	24	11.5	3.	2.	PER	30		
1750	1760	1525	KXF-5	34	16.	4.25	2.83	PER	30		
2500	2640	2385	KXF-7	51	24.	6.4	4.27	PER	30		
3500	3520	3050	KXF-9	68	32.	8.5	5.65	PER	60		
4250	4400	3810	KXF-11	85	40.	10.63	7.07	AEG	60	125	750
5000	5280	4570	KXF-13	102	48.	12.75	8.5	AEG	60	125	1000
6000	6150	5325	KXF-15	119	56.	14.9	10.	AEG	60	125	1000
7000	7050	6080	KXF-17	136	64.	17.	11.3	AEG	60	125	1500
8250	8360	7230	KXF-19	153	76.	19.15	12.75	AEG	100	125	1500
9500	9700	8360	KXF-21	170	88.	21.2	14.15	AEG	100	125	1500

Specifications for Landis Emergency Lighting Systems

(1) Furnish and install a complete Landis Emergency Lighting System for the control of all locations requiring auxiliary or emergency illumination.

(2) The purpose of emergency lighting system being to provide an independent source of illumination should the main supply of illumination fail or be interrupted.

Schedule of Outlets—

(3) The location of outlets to be controlled by emergency lighting system, with voltage and wattage to be used at each location are as follows:

Note: List names of rooms, with number of outlets and wattage required at each outlet.

(4) A total of outlets is required, with a total of watts.

(5) For standard illumination, all lamps shall be supplied from the main lighting supply. For the emergency lighting outlets, a minimum intensity of illumination of twenty-five one-hundredths of a foot candle shall be required for all main rooms, hallways and corridors, with a minimum intensity of illumination of five-tenths of a foot candle, on the floor at exit doors.

Control Panel—

(6) Furnish and install an Emergency Lighting Control Panel, Type at location as directed.

Note: Insert proper type, dependent upon voltage and wattage required.

(7) All equipment, consisting of switches, relays, voltmeter, ammeter, terminals, etc., shall be mounted on a slate panel not less than 1 in. thick, in. wide, in. high, enclosed in a surface steel cabinet, equipped with door, lock and key.

Note: PER-30 control panel is 24 in. wide, 30 in. high.
PER-60 control panel is 21 in. wide, 40 in. high.
All AEG control panels, 21 in. wide, 40 in. high.

(8) The control panel shall so function that circuits to all emergency lighting circuits shall be closed upon any interruption of the main lighting supply, or failure of any kind in the main lighting supply, providing illumination throughout the building on all emergency lighting circuits, automatically closed. Likewise, the emergency lighting circuits shall be automatically opened, upon the restoration of the main lighting supply.

(9) A manual switch shall be provided for initial charge of storage battery and for charging storage battery to its full capacity, after excessive loads have been placed upon battery.

Storage Battery—

(10) The storage battery for the control of the emergency lighting circuits shall be not less than ampere hours capacity, volts, capable of continuous operation of the system for at least 1½ hours at full load, Type

(11) The storage battery shall be of the glass jar type, with rubber covers. Same to be mounted on suitable racks at the location as directed. Hydrometer shall be provided for testing specific gravity of electrolyte.

Charging Units—

(12) The control panel shall be equipped with suitable tungar rectifier equipment for all PER control panels.

(13) The AEG control panel shall use a motor generator set for a charging unit, using a 110-volt, single-phase 60-cycle a-c. motor, direct connected to a volt d-c. shunt wound generator, watts.

Electric Clock Supervision—

(14) The control panel shall be connected to and controlled by an electric self-winding master regulator beat, Style, or in combination with an electric time and program clock system as separately specified.

Trouble Signals—

(15) The control panel shall be equipped with control relays to illuminate a lamp and sound a buzzer, when battery is not in proper condition or when there is a break in the emergency circuit leading to the automatic throw-over switch on control panel. The lamp and buzzer to be located in the ticket or motion picture booth, or in location as directed.

Wiring—

(16) All wiring for the emergency lighting system shall be in strict accordance with the rules of the National Board of Fire Underwriters.

Guarantee—

(17) The equipment, as above specified, shall be guaranteed against all original mechanical and electrical defects for a period of one year from date of completion of installation. Any alterations or repairs, by other than the manufacturer's representatives, shall render this guarantee null and void.

Engineering Service

Send us your floor plans with an elevation, for the building in which you would use a Landis Emergency Lighting System.

Our engineers will gladly lay out and properly locate emergency light outlets for you.

Specifications with conduit and wiring layouts will be prepared and submitted.

Some Representative Installations

- High School, Waynesboro, Pa.
- Pennsylvania State Forestry School, Mt. Alto, Pa.
- High School, Gettysburg, Pa.
- High School, Reinerton, Pa.
- High School, Elizabethtown, Pa.
- High School, Carlisle, Pa.
- Gettysburg College, Gettysburg, Pa.